



SPHEROS

WEBASTO BUS PRODUCTS

Air-conditioning system

**Installation and service
instructions
Roof-top air-conditioning
system Easysphere**

Easysphere

(prefilled)

03/2006

Id-Nr. 1103757A

CONTENTS

1. INTRODUCTION	4
1.1. Scope and purpose	4
1.2. Meanings of warnings, cautions and notes	4
1.3. Additional documentation required	4
1.4. Safety information and regulations	4
1.5. Certification	5
1.6. Corrections and improvements	5
2. GENERAL DESCRIPTION	6
2.1. Roof-top air-conditioner unit	6
2.2. Electrical components	9
2.3. Principle of operation of the air-conditioning system	9
2.4. Design, purpose and principle of operation of the assemblies	11
3. TECHNICAL DATA	13
3.1. Air-conditioning system	13
3.2. Electrical fuses	13
3.3. Compressor	14
3.4. Circuit diagram for basic version	15
3.5. Circuit diagram for deluxe version	16
4. INSTALLATION INSTRUCTIONS	17
4.1. Safety precautions	17
4.2. Installation kit	17
4.3. The following are not included in the installation kit and must be produced on site	17
4.4. Required equipment, special tools and accessories	17
4.5. Preparations on vehicle / cabin roof	17
4.6. Preparation of sealing frame	19
4.7. Make electrical connections	22
5. STARTUP	23
5.1. Safety precautions	23
5.2. Operator instructions	23
5.3. Controls and indicators	23
5.4. Putting into service for the first time	23
5.5. Operation	24
5.6. Operation of the air-conditioning system (deluxe version)	24

6. MAINTENANCE	25
6.1. Safety precautions	25
6.2. General	25
6.3. Maintenance and care	25
6.4. Maintenance and service checklist	26
6.5. Inspections before repair	26
6.6. Troubleshooting	27
6.7. Repairs	28
6.8. Post-repair procedures and testing	29
6.9. Visual inspection	29
7. WARRANTY CLAIMS	30

1. INTRODUCTION

1.1. Scope and purpose

This installation and service manual contains important information to assist trained personnel in the installation, operation and maintenance of the roof-top air-conditioning system CC8.

1.2. Meanings of warnings, cautions and notes

WARNINGS, CAUTIONS and NOTES in this manual have the following meaning:

WARNING

This heading is used to highlight that non-compliance with instructions or procedures may cause injuries or fatal accidents.

IMPORTANT

This heading is used to highlight that non-compliance with instructions or procedures may cause damage to equipment.

NOTE

This heading is used to highlight and draw specific attention to information.

1.3. Additional documentation required

- a) Operating manual, roof-top air-conditioning system CC4E

1.4. Safety information and regulations

The roof-top air-conditioning system CC4E has been designed and built in accordance with EC Directives. The system can be operated safely when installed and used correctly, in accordance with the installation and service instructions.

If the vehicle height specified in the vehicle's licensing documents is exceeded by installation of the roof-top air-conditioning system, this must be legalized by an official acceptance inspection in accordance with Section 19 of the German Road Traffic Licensing Regulations (StVZO).

The following general and operational safety regulations for the prevention of accidents have to be observed at all times:

- Safety regulations for the manufacture and operation of earth-moving machinery published by the foundation works association (Technischer Aufsichtsdienst (Technical Supervisory Services), Landsberger Str. 309, 80687 München)
- DIN ISO 3471 Roll-over protective installations
- DIN ISO 3449 Protective installations against falling objects
- DIN ISO 3411 Machine operator's body size, minimum working space
- Guidelines, safety rules, general rules and principles, and the data sheets issued by the committees of the Central Health and Safety Office - BG7 - of the Central Association of Manufacturing Employers' Liability Insurance Associations (published by: Carl Heymanns Verlag KG, Luxemburger Strasse 449, D-50939 Köln).

"General safety regulations" beyond the scope of these regulations are detailed below.

The specific safety regulations applicable to this manual are highlighted in the individual chapters by WARNINGS, CAUTIONS and NOTES.

General safety regulations

Non-compliance with the installation manual and its procedures will void the Webasto warranty. The same applies to unskilled repairs or repairs not using original spare parts.

Electrical wiring and operating elements of the air-conditioning system must be arranged in the vehicle in such a way that their correct functioning cannot be impaired under normal operating conditions.

Safety instructions for maintenance

If faults develop in the refrigerant circuit, the system must be tested and repaired by an authorized specialist repairshop. Under no circumstances may refrigerant be discharged into the atmosphere (refer to Section 8 of the regulation dated 6 May 1991 banning CFCs and halones).

Never heat refrigerant cylinders with a naked flame.

Liquid refrigerant must never be allowed to come into contact with the skin.

Always wear protective clothing and goggles when handling refrigerant.

WARNING

Do not perform soldering or welding directly on components of the closed refrigerant circuit or in its vicinity. The heating will cause a rise in the circuit pressure. There is a danger of explosion.

Before performing any work allow the system to cool down completely. Risk of injury due to burns on the condenser, compressor and hoses.

Installation, maintenance and repair work must be carried out by duly qualified personnel. Such work may only be undertaken with the engine off and the power supply switched off.

The battery must be disconnected before opening the roof-top air-conditioner, removing the compressor or starting any work on the electrical wiring.

Do not wear metal jewellery (bracelets, watches, necklaces, rings) when working on the air-conditioning system.

1.5. Certification

- a) The electro-magnetic compatibility (EMC) has been checked
- b) to meet the EN 45014 standard requirements.
- c) The CE mark has been affixed to the roof-top air-conditioning system.

1.6. Corrections and improvements

Complaints, improvements and suggestions for correcting this manual should be addressed to:

Spheros GmbH
Kraillinger Straße 5
D-82131 Stockdorf
Telefon: +49 (0)89 857 94-1300
Telefax: +49 (0)89 856 24 17

2. GENERAL DESCRIPTION

The roof-top air-conditioning system CC4E (1) contains all the documents required for installation and operation. Electric power is supplied by the on-board vehicle supply via cables (2). The system is designed for operation with 24 V.

The roof-top air-conditioning system is designed for the cooling / air-conditioning of buses as well as the air-conditioning of the driver's area in buses.

The system is prefilled with refrigerant (R134a) and need only be connected to the on-board power supply when installed.

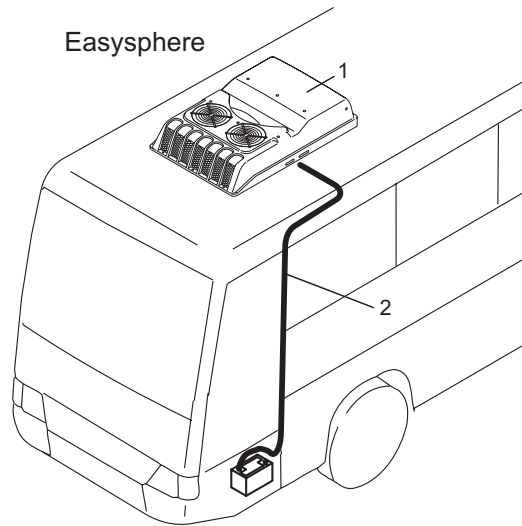

Fig. 2.1

2.1. Roof-top air-conditioner unit

The roof-top unit is shown in Fig. 2.2.

It comprises:

- Hood (1) as external contour element, with openings and protective grilles for air inlet and outlet.
- Baseplate (8) as the load-bearing structural element.

The following are integrated into the baseplate:

- Radial fan (5)
- Receiver-drier (13) with sight glass (14) and pressure switch (15)
- Condenser (3)
- Evaporator (6) with mist separator (7)
- Expansion valve (11)
- Anti-icing switch (12)
- Screw connections (9, 10)
- Relay (16) and holder (17) for blade-type fuses
- Cable harness with grommet (26)
- Axial fan (4)
- Electric motor (28)
- Compressor (27)
- Refrigerant hoses (29/30)
- Connecting pins (+/-) (31)

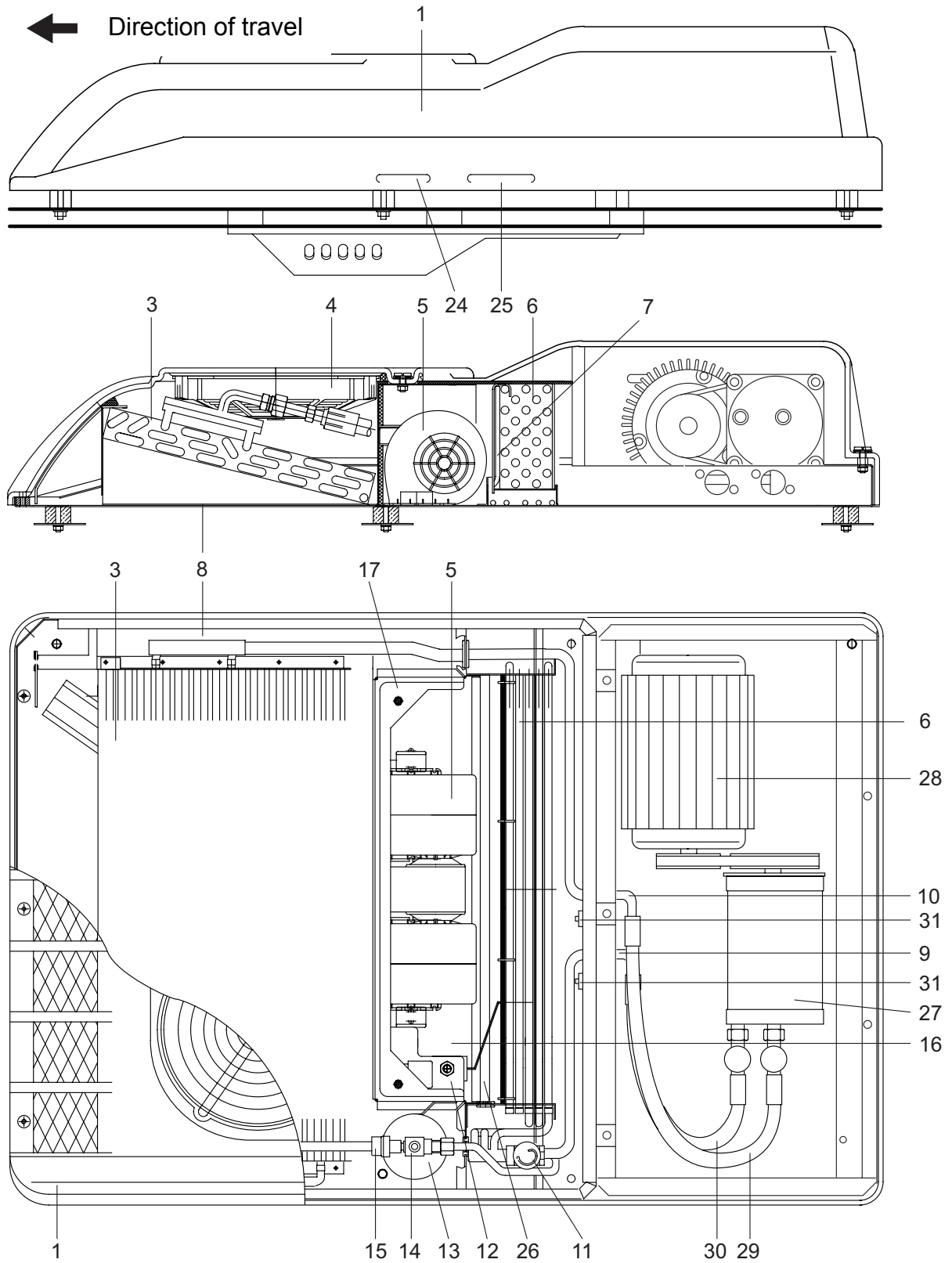

Fig. 2.2

Roof-top air-conditioning system Easysphere

The air distribution panel (Fig. 2.3) is not included in the scope of supply.

The following operating elements: ON / OFF rocker switch (1) and fan rocker switch (2) can be integrated into the air distribution panel.

An electronic room thermostat is additionally integrated into the roof-top unit in the deluxe version. A set-point potentiometer (3, Fig. 2.3) is supplied for setting the temperature and can be integrated into the air distribution panel..

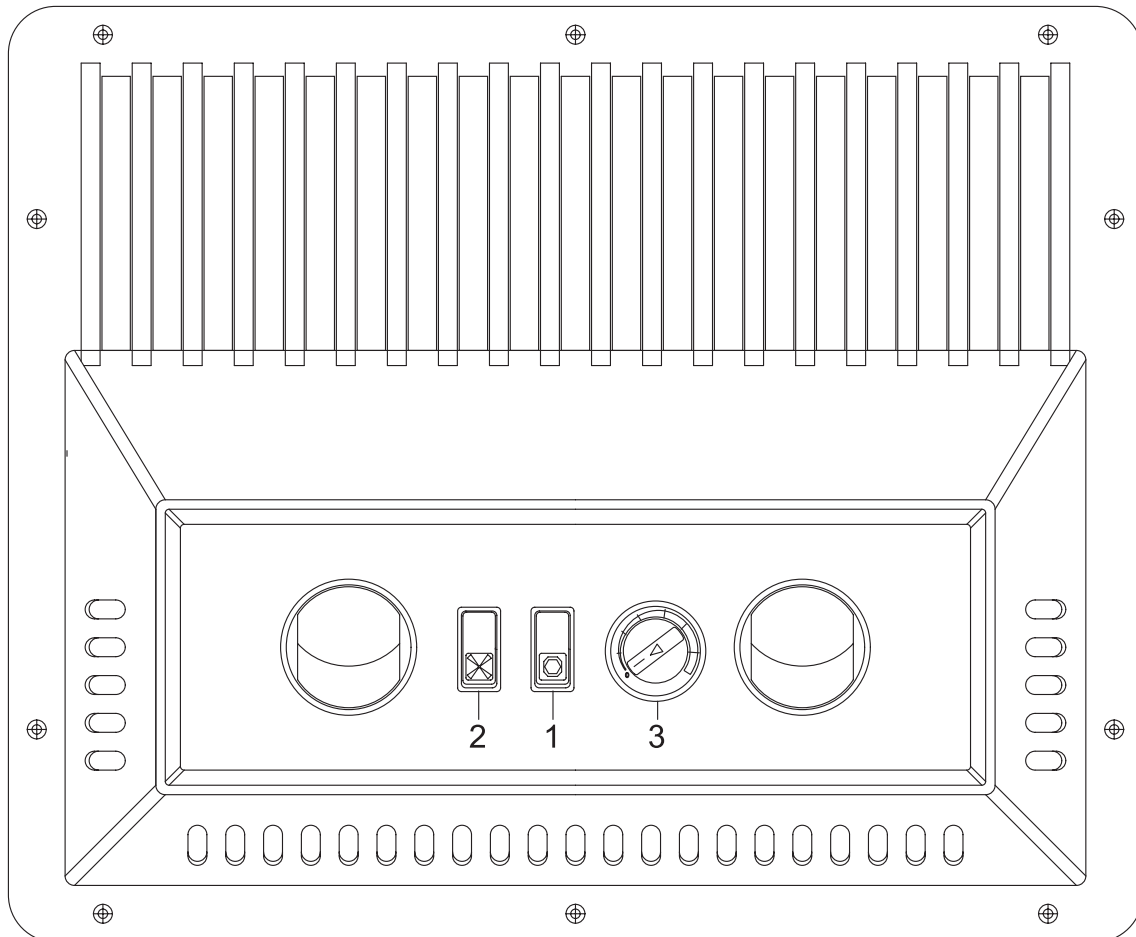

Fig. 2.3

- (1) Air-conditioning system ON / OFF
- (2) 3-position rocker switch
- (3) Setpoint potentiometer (optional)

2.2. Electrical components

Electrical connections for the equipment are made as shown in the circuit diagrams Figs. 3.1 and 3.2.

The roof-top air-conditioning system is equipped with a protective circuit to prevent total exhaustion of the battery. The system is switched off automatically if the power supply drops below 20 V for more than 10 seconds. It is restarted by repeatedly switching on.

If the system is only to be operated when the engine is running, a working contact relay must be installed and connected via terminal D+/61 from the alternator (see circuit diagram on page 16).

The electronic system for the motor includes a soft-start function to prevent current peaks being transmitted to the on-board supply. In addition, the electric motor is switched off automatically in the event of overloads (i.e. current consumption > 80 A for more than 1 second) due to possible system damage.

Restarting is effected by repeatedly switching on the system.

The electric motor is switched off automatically to prevent damage to the electronics at temperatures of less than +5 °C or more than +96 °C.

2.3. Principle of operation of the air-conditioning system

When the air-conditioning system is switched on via the ON / OFF rocker switch, the electric motor starts up and drives the compressor via a poly-V-belt. The compressor compresses the refrigerant gas and delivers it to the condenser (3) where it condenses and gives off heat.

The resultant condensation heat is transferred to the outside air flowing through the condenser (19 and 20, Figs. 2.4 and 2.5). Two axial fans (4) maintain a sufficient air flow even when the vehicle is stationary.

The liquid refrigerant flows through the receiver-drier (13) to the expansion valve (11), where it expands as a result of the controlled pressure drop and then reverts to the gaseous state in the evaporator (6), absorbing heat at the same time.

The hot air (21) circulating in the driver's cab is drawn in by the radial fan (5), cooled in the evaporator, dried and returned to the cab via the air-distribution panel (22). The resultant condensation water is collected and discharged into the atmosphere via the drain outlet (25).

During operation, the refrigerant circuit is monitored by the anti-icing switch (12) (S4, see circuit diagram Fig. 3.1 or 3.2) and the pressure switch (15) (S3, see circuit diagram Fig. 3.1 or 3.2). The electric motor and consequently also the compressor are monitored via these two switches.

When the air-conditioning system is switched off via the ON / OFF rocker switch, the electric motor and the fan motors are de-energized. The refrigerant circuit and recirculating-air circuit are switched off.

Rainwater entering the roof-top system is discharged via the drain outlet (24, Fig. 2.2).

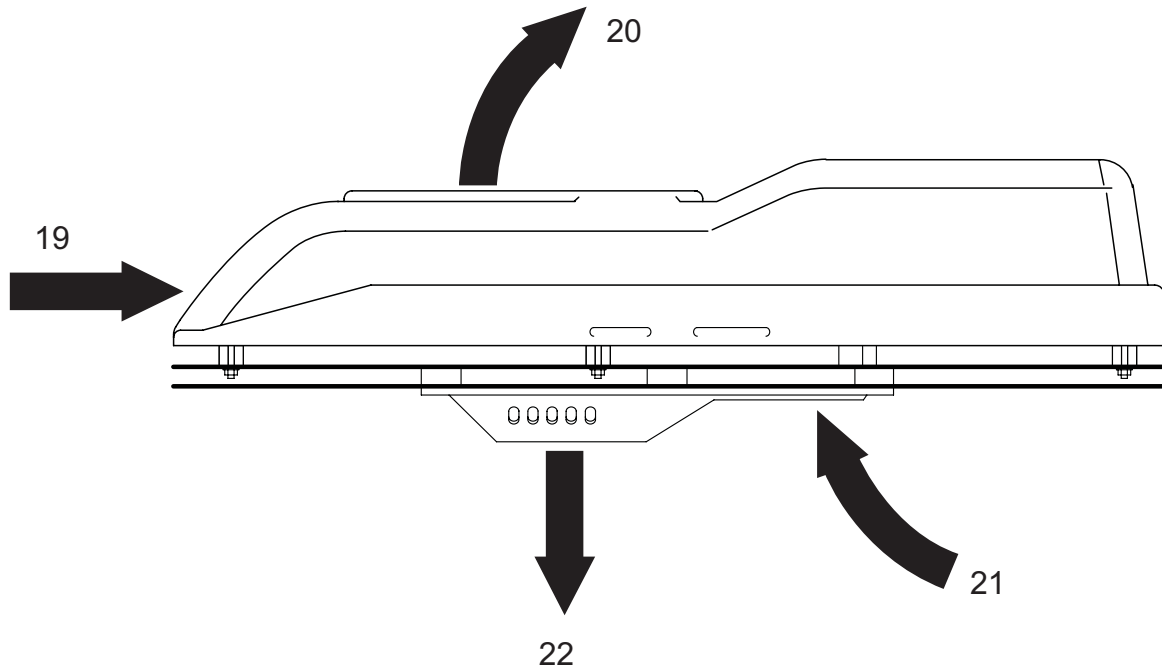

Fig. 2.5

2.4. Design, purpose and principle of operation of the assemblies

Condenser

The condenser (3, Fig. 2.2) consists of a continuous pipe coil and fins interconnected to form a large heat exchanger surface.

It cools the hot refrigerant gas so that the latter liquefies and undercools. At the same time, it transfers the condensation heat to the outside air flowing through it via the fins.

Receiver-drier

The receiver-drier with sight glass (13, Fig. 2.2) is an expansion and storage reservoir for refrigerant. Its lower part contains a granulated desiccant which extracts and chemically binds small amounts of water from the refrigerant. During operation, the level can be checked in the sight glass (14, Fig. 2.2) to ensure that there is sufficient refrigerant in the circuit.

Thermostatic block valve

The thermostatic **block valve** (11, Fig. 2.2) regulates the flow of refrigerant to the evaporator as required and in accordance with the temperature in the evaporator. The thermostatic expansion valve represents the control element between high and low-pressure part of the refrigerant circuit.

Evaporator

The evaporator (6, Fig. 2.2) is basically of the same design as the condenser. The refrigerant flowing through the pipe from the expansion valve changes from the liquid to the gaseous state and superheats in the evaporator.

The required evaporation heat is extracted from the cabin air flowing through the fins and is transmitted through the pipe to the refrigerant. The air dries as it cools and condensation water is drained overboard. The mist separator (7, Fig. 2.2) prevents droplets of condensation being drawn in by the radial fan and entering the interior of the vehicle.

Roof-top air-conditioning system Easysphere

Pressure switch

The pressure switch (15, Fig. 2.2) includes a high-pressure and a low-pressure switch. It monitors the pressure in the high-pressure part of the refrigerant circuit and switches off both the electric motor and the compressor if the pressure is too low (e.g. due to loss of refrigerant) or too high (e.g. due to overheating in the condenser).

Anti-icing switch

The anti-icing switch (12, Fig. 2.2) is a temperature switch. It measures the temperature between the evaporator fins and switches off the power supply to the electric motor if there is any risk of ice forming (approx. 0 °C) and back on again at approx. 3 °C.

Axial fan

The two axial fans (4, Fig. 2.2) comprise a DC motor, fan wheel, housing and protective grille. When the air-conditioning system is switched on, they draw a constant supply of power from the on-board system via relay K1 (Fig. 3.1) and supply the condenser with the required outside air.

Radial fan

The radial fan (5, Fig. 2.2) is of the multi-speed type. It draws the cabin air through the evaporator and blows the air back into the cabin via the nozzles in the air-distribution panel (Fig. 2.3).

Compressor

The compressor (27, Fig. 2.3) comprises a swashplate compressor and a magnetic coupling with belt pulley. It is driven at constant speed by an electric motor (28, Fig. 2.2). When in operation, it compresses the refrigerant to the required condensation pressure.

Electronic room thermostat (optional)

An electronic room thermostat and temperature sensor are integrated in the deluxe version. The intake air temperature is measured. The electric motor is switched off when the temperature set on the setpoint potentiometer is reached.

Electric motor

The electric motor (28, Fig. 2.2) drives the compressor via a poly-V-belt. The electronic system in the motor includes a soft-start function to prevent current peaks being transmitted to the on-board supply. In addition, the electric motor is switched off automatically in the event of undervoltage (< 20 V for more than 10 seconds) or overload (current consumption > 80 Amp for more than 1 second). It is restarted by repeatedly switching on the system.

The electric motor is switched off automatically at temperatures of less than +5 °C or more than +96 °C.

3. TECHNICAL DATA

3.1. Air-conditioning system

Designation	Type Easysphere
Dimensions, roof-top unit	
Length x width x height	1.110 mm X 774 mm X 215 mm
Weight	approx. 55 kg
Operating voltages (depending on vehicle's electr. system)	24 Volt DC
Current consumption	
Total current consumption	max. 68 A
– Electric motor	53 A
– Condenser fan	10 A
– Compressor fan	5 A
Switching points, low-pressure switch	
– Off	2.1 ± 0.3 bar
– On	2.0 ± 0.2 bar
Switching points, high-pressure switch	
– Off	26.5 ± 2 bar
– On	20 ± 2 bar
Refrigerant, max. ambient temperature 45 °C	R134a
Power rating at 46% rel. humidity, inside temperature 27 °C, outside temperature 35 °C	3.5 kW
Evaporator air flow rate (air flow unobstructed)	550 m ³ /h
Switching point, anti-icing thermostat	
– Off	1 °C ± 1
– On	3.5 °C (Max)
Refrigerant capacity (R134a) (prefilled)	900 g

3.2. Electrical fuses

Protected components	Fuse Designation	Ratings
24 V		
– Radial fans + compressor	F2	15 A
– 2 axial fans	F3	15 A
– Electric motor	-	75 A

Roof-top air-conditioning system Easysphere

3.3. Compressor

Designation

Type Sanden 5D5 H09

Dimensions (length x width x height)

183 mm X 124 mm X 124 mm

Sense of rotation

clockwise

Stroke volume per revolution

87 cm³

Lubricating oil for refrigerating compressors
(type, quantity)

PAG 150 cm³

Refrigerant connections

– Delivery side (standard)

3/4" O-ring

– Intake side (standard)

7/8" O-ring

Installation position, range of tilt

– About longitudinal axis

max. ± 30°

– About lateral axis

max. ±10°

Magnetic clutch

– Power supply

24 Volt DC

– Power consumption

max. 34 Watt

– Connector type

DIN 46343 - AMP 6.3

3.4. Circuit diagram for basic version

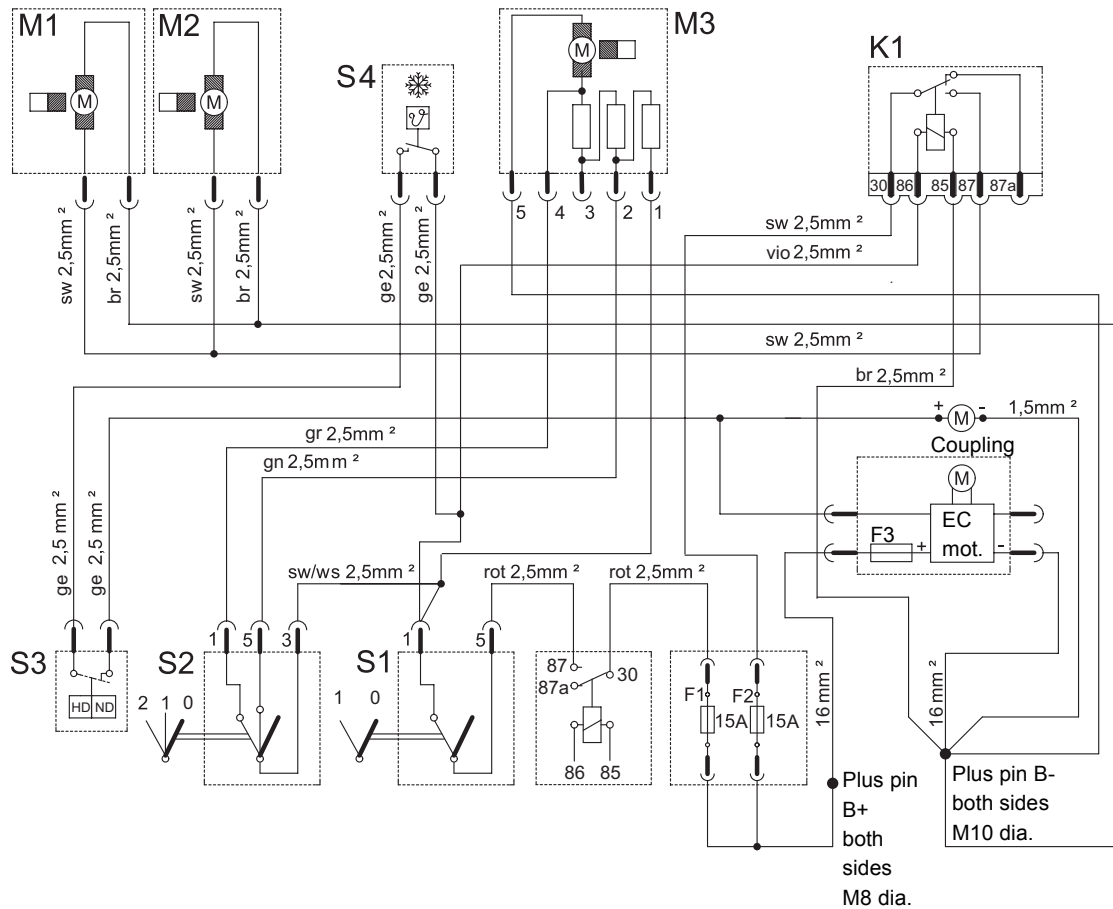

Nomenclature	Pos	24 V
Fuse	F1,F2	15 A, 15 A
Fuse socket, 4-fold	FA	81676
LP/HP (HD/ND) switch	S3	66553
Anti-icing switch	S4	65345
Relay	K1	34098
Rocker switch	S1,S2	66596,66595
Axial fan	M1,M2	64506
Radial fan	M3	80866
Prot. against reversed polarity	F3	75 A

	Cable size (vehicle side)		
	+	Ground	Compressor
24 V version	16 mm ²	16 mm ²	2.5 mm ²

$$A = \frac{L \times I}{\text{Kappa} \times U} = \frac{12 \text{ meters} \times 70 \text{ amps}}{56 \times 1.0 \text{ volt}} = 15 \text{ mm}^2$$

selected standard cross-section = min. 16 mm²

$$A = \frac{L \times I}{\text{Kappa} \times U} = \frac{20 \text{ meters} \times 70 \text{ amps}}{56 \times 1.0 \text{ volt}} = 25 \text{ mm}^2$$

selected standard cross-section = min. 25 mm²

A = cable cross-section

L = cable length in meters

I = max. current

Kappa = specific conductivity of copper cables

U = max. permissible voltage drop

Fig. 3.1

Roof-top air-conditioning system Easysphere

3.5. Circuit diagram for deluxe version

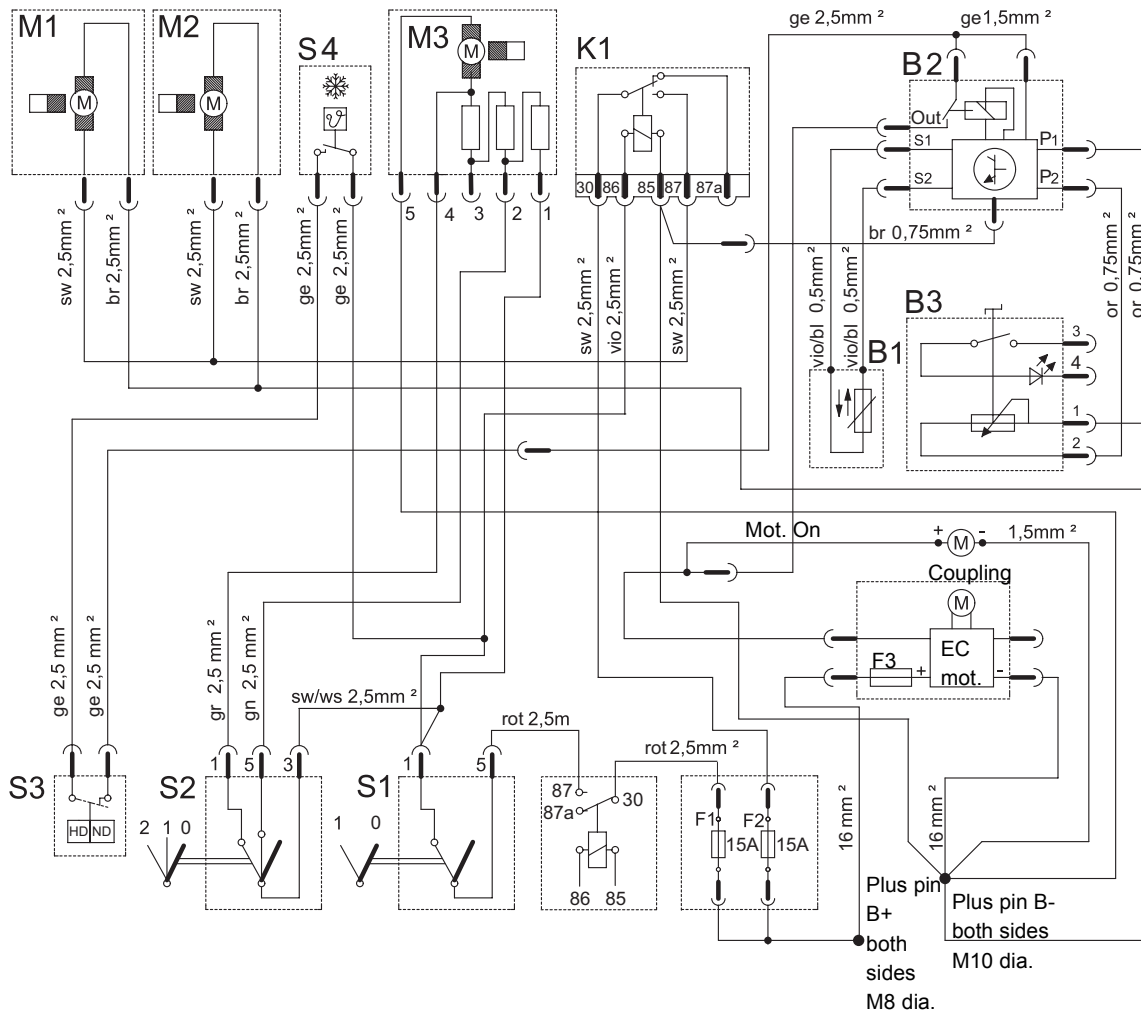

Nomenclature	Pos	24 V
Temp.selector	B3	83051
Thermostat module	B2	66784
Temperature sensor	B1	Philips KTY 81-110
Fuse	F1,F2	15A, 15A
Fuse socket 4-fold	FA	81676
LP/HP (HD/ND) switch	S3	66553
Anti-icing switch	S4	65345
Relay	K1	34098
Rocker switch	S1,S2	66596,66595
Axial fan	M1,M2	64506
Radial fan	M3	80866
Prot. against reversed polarity	F3	75A

	Cable size (vehicle side)		
	+	Ground	Compressor
24V version	16mm ²	16mm ²	2.5mm ²

$$A = \frac{L \times I}{\text{Kappa} \times U} = \frac{12 \text{ meters} \times 70 \text{ amps}}{56 \times 1.0 \text{ volt}} = 15 \text{ mm}^2$$

selected standard cross-section = min. 16 mm²

$$A = \frac{L \times I}{\text{Kappa} \times U} = \frac{20 \text{ Meter} \times 70 \text{ Ampere}}{56 \times 1,0 \text{ Volt}} = 25 \text{ mm}^2$$

selected standard cross-section = min. 25 mm²

A = cable cross-section
 L = cable length in meters
 I = max. current
 Kappa = specific conductivity of copper cables
 U = max. permissible voltage drop

Fig. 3.2

4. INSTALLATION INSTRUCTIONS

4.1. Safety precautions

The safety instructions set out in chapter 1.4 must be read and noted before starting work.

Installation should be performed by someone well versed in auto mechanics.

4.2. Installation kit

In addition to the main components, i.e. the

- roof-top air-conditioning unit

the basic scope of supply also includes the following parts and materials:

- d) For mounting the roof-top air-conditioning unit with air-distribution panel
 - 10 self-tapping screws
 - Sikaflex sealing compound
 - 3 Armaflex sealing strips
 - 9 silent blocks with bolts and nuts

4.3. The following are not included in the installation kit and must be produced on site

- Air duct frame between roof and air-distribution panel
- Connecting cables and elements (vehicle side) (see Fig. 3.1 or 3.2)
- Fastening elements for routing the connecting cables
- Reinforcing elements, hoops inside the roof to ensure sufficient roof stability

4.4. Required equipment, special tools and accessories

- a) The system is already prefilled (R134a)
 - Sheet metal cutter for breakthroughs in vehicle / cabin roof
 - Mechanics tool kit
- b) For service (evacuation, filling and testing the refrigerant circuit)
 - Servicing / recycling station for refrigerant R134a
 - Vacuum pump, suction rate min. 5 m³/h, final pressure 1 mbar
 - Filler hoses with quick-disconnect couplings for R134a
 - Leakage tester
 - Digital thermometer
 - Refrigerant R134a
 - PAG oil for A/C compressors
 - Test fittings with intake-pressure and high-pressure gauges

4.5. Preparations on vehicle / cabin roof

- Installation depends on the type of vehicle. The vehicle manufacturer's instructions must therefore be observed.
- Fig. 4.1 shows the installation dimensions and the mounting hole pattern of the roof-top unit. The breakthroughs for the air intake and discharge openings are located off-centre in the baseplate.

IMPORTANT

Ensure that load-bearing elements (e.g. roof hoops, reinforcements) and installed parts are not damaged.

- Cut template out of packaging material.
- Remove intermediate roof / insulating material around the air ducts.
- Mark the air duct openings (shaded areas, Fig. 4.1) on the roof and cut them out.
- Align the template or roof-top air-conditioning unit (without hood) with the marked point and drill nine holes with dia. 9 mm.
- Remove template or roof-top unit as applicable.
- Deburr / smooth the cut edges of the openings and drilled holes and coat with corrosion-proofing paint.
- Prepare inner roof so that the air-distribution panel can be installed under the roof (see Fig. 4.3).

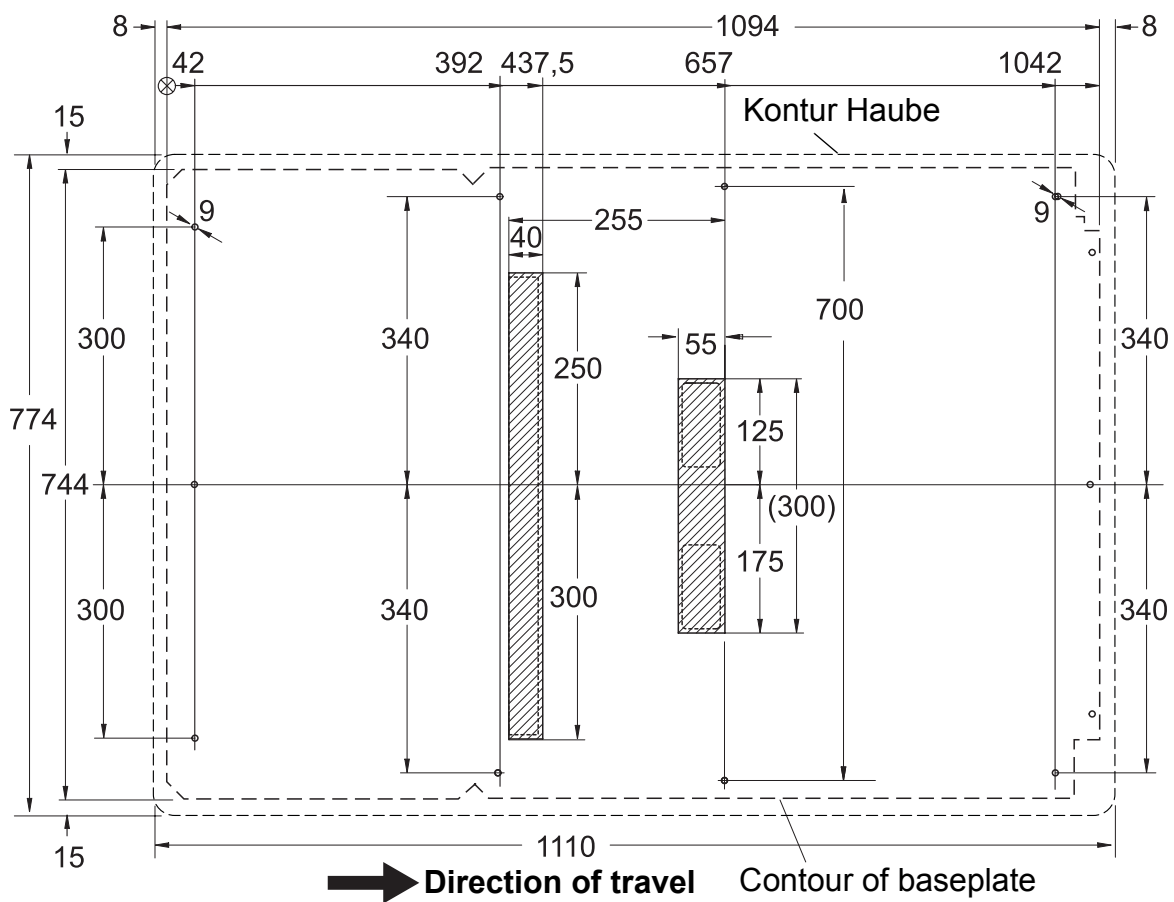

Drilling pattern (viewed from above, onto the roof of the vehicle)

Fig. 4.1

NOTE

The breakthroughs for the air intake and discharge opening are located off-centre.

4.6. Preparation of sealing frame

- c) The height of the sealing frame must be cut / adapted to the roof contour (beads/gutters/camber) in such a way as to seal the contours as shown in Fig. 4.2.
The sealing strips should be compressed by approx. 20% - 40% in height when fitting the air-conditioning unit.
- d) Affix the sealing profile to the roof with the Sikaflex 221 included in the installation kit as shown in Fig. 4.3.
- e) Coat the top of the sealing profile with Sikaflex sealing compound.

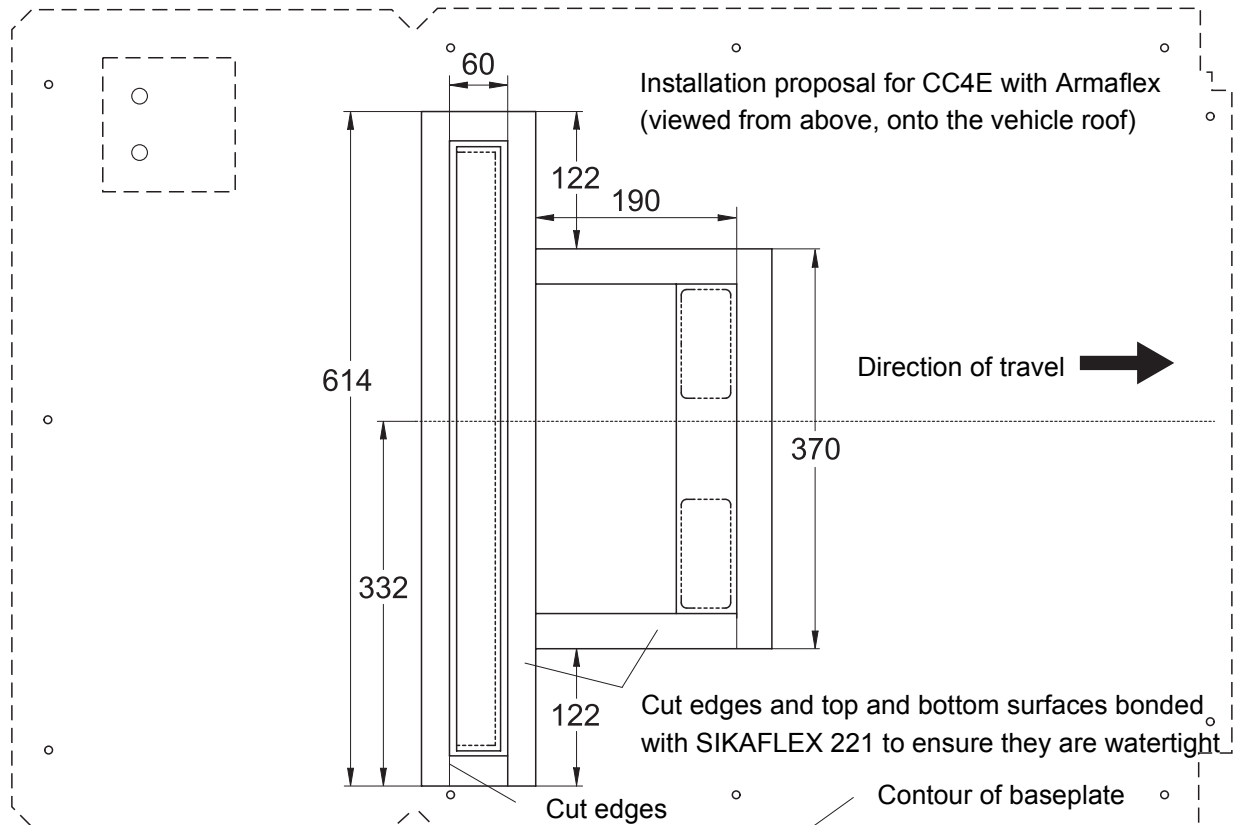

Fig. 4.2

NOTE

The curing time of 3-5 hours must be observed when using Sikaflex 221 for installation of the roof-top air-conditioning system. Mount the baseplate before Sikaflex has cured. Do not expose seal to moisture before Sikaflex has cured.

Roof-top air-conditioning system Easysphere

Mounting the baseplate

- a) Place the baseplate on the roof (sealing frame) and align it. Place silent blocks under the eight fastening points and insert the nine M8 bolts (with washers) into the holes (Fig. 4.3).

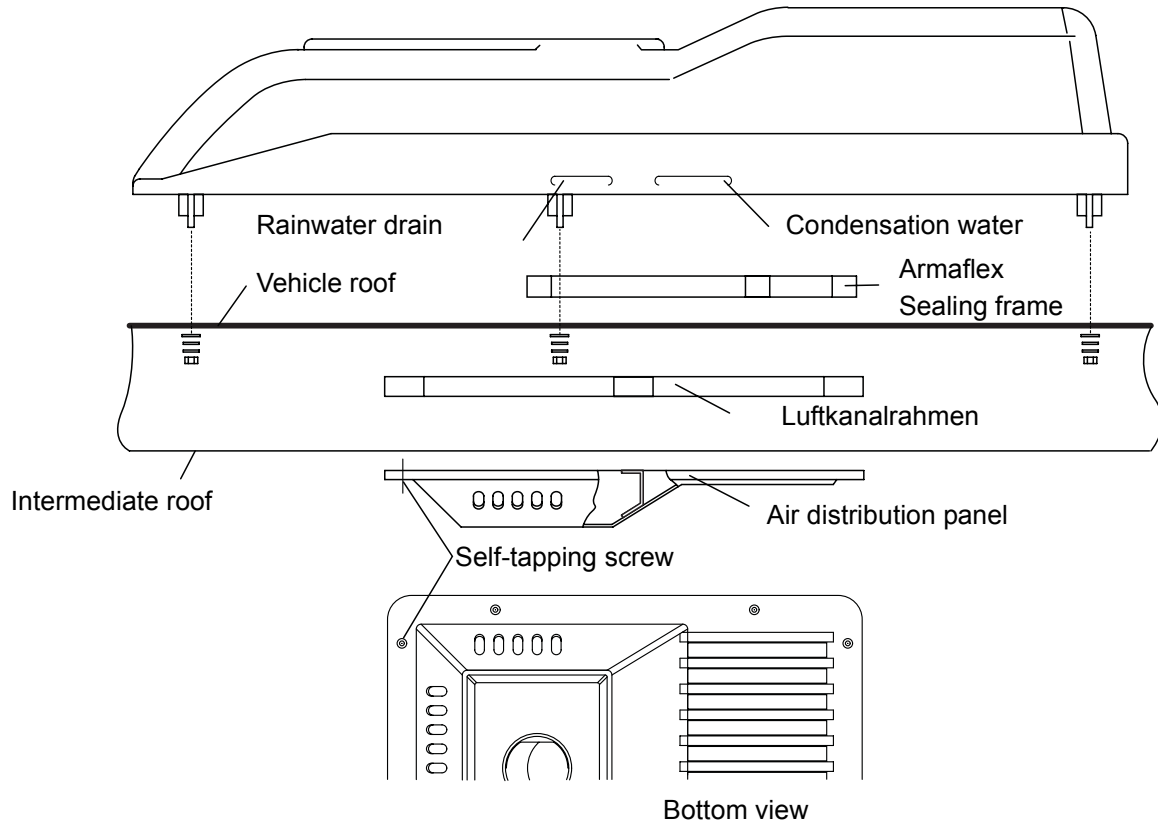

Fig. 4.3

- b) Check that the baseplate has been positioned correctly and screw it tightly into place with the washers, serrated washers and nuts included in the installation kit (tightening torque 9 Nm).

IMPORTANT

Ensure that moisture can escape between the vehicle roof and the baseplate. When sealing the sealing frame, care must be taken to ensure that the drains for condensation and rainwater remain free. Other seals in addition to those described here using Sikaflex 221 and the Armaflex sealing frame are therefore not permitted.

Pre-assembly of air-distribution panel

The rocker switches and the setpoint potentiometer (if applicable) must be installed in the air-distribution panel, depending on the individual version and scope of supply.

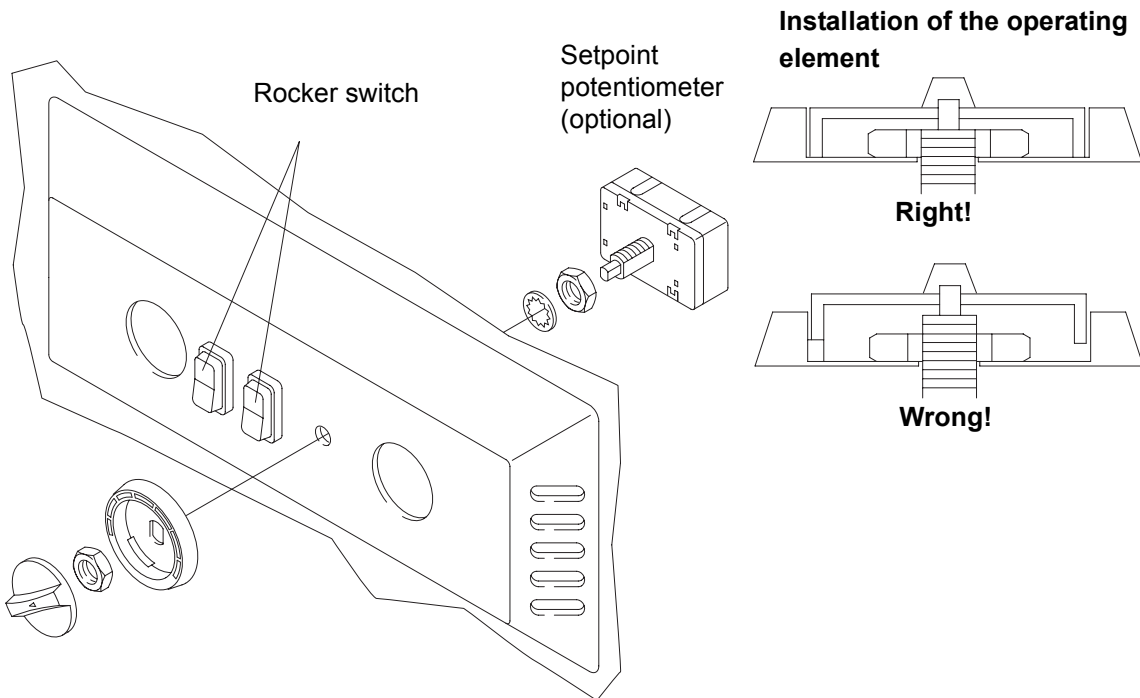

Fig. 4.4

Installation of the rocker switches:

Locate rocker switches in rectangular cut-outs of air distributor panel so that they engage (Fig. 4.4).

Installation of the setpoint potentiometer:

Insert the setpoint potentiometer in the hole in the air distribution panel as shown in Fig. 4.4.

The wiring harness is prepared for connection to the command value switch potentiometer (mechanical). Simply pull on connector housing to unplug the connector. By pulling on the cable loom the terminal plug is arrested (self-locking).

NOTE

The light conductor must make contact with the rotary selector.

Installation of air distribution panel

- a) Prepare the air duct frame (if necessary) so that it creates an effective seal on all sides and the top of the intake and delivery area between the vehicle roof and the intermediate roof.
- b) Secure the air duct frame to the roof. Ensure that the fitted roof-top air-conditioning system is not damaged when drilling holes.
- c) Connect cables between the air distribution panel (S1 and S4 in circuit diagram, Fig. 3.1 or 3.2) and the baseplate.
- d) Position the air distribution panel as shown in Fig. 4.3 and secure it with ten self-tapping screws to the intermediate roof or to suitable self-made brackets if necessary. If the optional recirculating-air filter has also been ordered, it must be inserted in the intake area of the air distribution panel.

Roof-top air-conditioning system Easysphere

NOTE

The air distribution panel must not be aligned with the centre of the air intake opening. The air distribution panel must cover the air intake opening in the vehicle roof.

4.7. Make electrical connections

The system must be adequately protected by fuses on the vehicle side. The cable cross-section must be determined by the customer in accordance with the cable length.

Refer also to "Copper cables for use in motor vehicles" DIN VDE 0298 Part 4.

a) Disconnect vehicle battery.

IMPORTANT

- Note the vehicle manufacturer's instructions when connecting the power supply for the air-conditioning system.
- Only adequately dimensioned cables approved for use in motor vehicles may be used (see Fig. 3.1 or 3.2).
- Work on the electrical system may only be performed by authorized personnel.
- Rubber grommets must be used when routing cables through metal sheets.

b) Make and connect the cables as shown in Fig. 3.1 or 3.2.

- Route cables through protective sleeves and secure them appropriately with cable ties.
- The power supply for the system must be connected to the bulkhead (Fig. 2.2) with the cable bolts provided for this purpose.

IMPORTANT

Correct polarity must be ensured without fail (+ pole: M8 cable bolt, - pole: M10 cable bolt). The electronic control will be destroyed if the polarity is reversed!

- Use strain relief material.

NOTE

If the operating elements are not installed in the air distribution panel, the optionally available cable set for external installation of the operating elements can be used to extend the connecting cables.

5. STARTUP

5.1. Safety precautions

The safety instructions in chapter 1.4 must be observed.

IMPORTANT

The system may only be started when the hood has been fitted. Risk of injury due to motor fans, belts and the compressor coupling.

5.2. Operator instructions

IMPORTANT

The air-conditioning system can only be put into operation with the vehicle engine running.

5.3. Controls and indicators

The roof-top air-conditioning system is operated via the two rocker switches (Fig. 5.1):

- Air-conditioning system ON / OFF (1)
- 3-position rocker switch (2) .

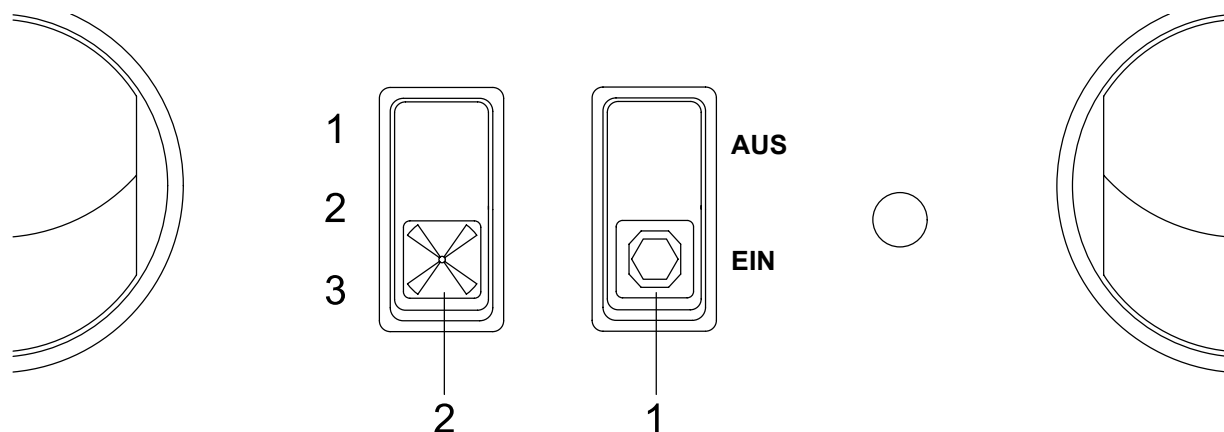

Fig. 5.1

5.4. Putting into service for the first time

- a) Start the vehicle engine as described in the owner's manual.
- b) Switch on system using ON / OFF switch. Operate system at maximum fan power (3-position rocker switch in position stage 3). Cold air must emerge from the air distribution panel after at least 2 minutes.
- c) Reduce fan speed and check airstream.

Roof-top air-conditioning system Easysphere

5.5. Operation

NOTE

Note the instructions in chapter 5.2.

Prior to operation ensure that:

- air conditioning system is in serviceable condition.
- air inlets and outlets are unobstructed (no leaves, etc.)
- condensation water drain holes are unobstructed.

Operation of the system:

- a) The system is controlled by means of the rocker switches ON / OFF and the fan switch.
- b) The interior of the vehicle is cooled in recirculation mode, in keeping with the set fan speed 1, 2 or 3.
- c) The temperature of the air-conditioning system CC4E without electronic room thermostat is controlled via the anti-icing thermostat in the system, which switches off the electric motor when the temperature at which ice forms on the evaporator is reached. The evaporator and condenser fans continue to run. The electric motor is switched on again when the threshold temperature of the anti-icing thermostat is exceeded.
- d) Manual control of the cooling performance may be achieved by means of fan power stage selection.
Stage 1: low cooling performance at low air outlet temperature and low fan power
Stage 2: mid cooling performance at mid air outlet temperature and mid fan power
Stage 3: high cooling performance at somewhat higher air outlet temperature and maximum fan power

NOTE

In order to cool and dehumidify the interior of the vehicle after standing for a long time in high outside temperatures and direct sunlight, it is advisable to switch the fan to speed 3 at first. It can then be turned down to speed 2 or 1, depending on the outside temperature, when a pleasant temperature has been achieved inside the vehicle.

5.6. Operation of the air-conditioning system (deluxe version)

Operation is as described in 5.5 for the basic version.

In addition, the temperature can be selected via a setpoint potentiometer (optional) with knob. The electric motor is switched off when the set temperature is reached. The electric motor is switched on again when the temperature increases again by approx. 2 °C.

6. MAINTENANCE

6.1. Safety precautions

The safety instructions and regulations in chapter 1.4 must be observed.

6.2. General

- a) Work on the refrigerant circuit may only be carried out by qualified personnel from duly authorized specialist repairshops.
- b) The special equipment, tools and accessories listed in chapter 4.5 are required and must be used for maintenance work on the refrigerant circuit.
- c) Like all parts of the vehicle, the air-conditioning system is subject to constant stresses. The specified maintenance work must be carried out regularly in order to ensure troublefree operation of the system and avoid damage to the components.
- d) Proper handling of the system and a complete record of all the required scheduled maintenance are essential for acceptance of possible warranty claims concerning damaged components subject to maintenance.
- e) To prevent not only the shaft seals of the refrigerant compressor drying out, but also moving parts in the refrigerant circuit from seizing up due to resinification of the oil, the air-conditioning system must be switched on for approx. 15 minutes at least once per month when it is not in regular use. Requirement: Minimum outside temperature > 5 °C or heated hall.

6.3. Maintenance and care

- a) Regardless of the following schedule, all screw connections securing the roof-top air-conditioning system must be checked within four weeks of using the system for the first time in order to ensure that they are secure.
- b) Even if the air-conditioning system is not operated, individual components are subject to wear due to normal ageing or stress due to vehicle operation. All checks listed in the maintenance and servicing plan must therefore be performed regardless of the system operating hours.
- c) Even if hose connections do not leak, refrigerant may be lost regardless of operating hours. Due to the structure of the material used for the refrigerant hoses, their diffusion rate can vary depending on ambient temperature. However, a leak must be assumed to exist somewhere in the system if relatively large quantities of refrigerant are lost at short intervals.
- d) Slight contamination of evaporator and condenser fins is removed with compressed air applied against normal direction of air flow. Major contamination or greasy deposits must first be removed with soapy water or a suitable cleaning solvent (not aggressive for copper or aluminum) before cleaning with compressed air or a water jet.
- e) The receiver-driver must be replaced at least once per year and whenever work has been performed on the refrigerant circuit.
- f) The filter mat must be replaced at regular intervals

IMPORTANT

Refrigerant must never be discharged into the atmosphere (refer to Section 8 of the regulation dated 6 May 1991 banning the use of CFCs and halones).

Roof-top air-conditioning system Easysphere

6.4. Maintenance and service checklist

System component	Maintenance task	Frequency		
		m	6m	a
Refrigerant circuit				
– Hoses	Check for chafing and general condition		X	
– Connections	Test for leaks with leak tester			X
– Refrigerant quantity	Check refrigerant level in sight glass	X		
– Condenser	Check condition of fins (must be cleaned if soiled)		X	
– Receiver-drier	Replace			X
– Condensation water drain	Check that opening is clear and clean if necessary		X	X
– Roof-top air-conditioner unit	Check overall condition and secure attachment of connections			
Compressor				
– Magnetic clutch	Check engagement without slip / compressor start-up		X	
– Compressor	Check noiseless operation		X	
– Poly-V-belt	Check serviceability and tension			X
– Mounting bracket	Check condition and secure attachment			X
Electrical connections				
– Wiring	Check undamaged condition		X	
– Connections	Check undamaged condition and secure attachment		X	
– Motor connections	Check for signs of oxidation			

Abbreviations: m – monthly, a – yearly (a – every six months if operated throughout the year)

6.5. Inspections before repair

In order to avoid unnecessary disassembly or duplication of work, the overall condition of the air-conditioning system must be checked before starting any repairs.

Visual inspection

- a) Outer condition of roof-top unit:
 - Hood without cracks and no damage to paint finish
 - Air inlets and outlets clean and undamaged
 - Attachment points secure and without corrosion
 - Hose and wiring connections serviceable
 - Openings in metal undamaged.
- b) Condition of air distribution panel
 - Attachment points / screws secure
 - Ventilation switches serviceable
 - Circulating air inlet / outlet screen undamaged and clean.
- c) Condition of compressor
 - Hose connections undamaged and secure
 - Attachment parts / screws secure.

Poly-V-belt correctly tensioned
 Poly-V-belt and V-belt pulleys undamaged
 Electrical connection undamaged

6.6. Troubleshooting

General

- a) A systematic approach is advisable for troubleshooting. Appropriate action must be undertaken as described below for faults of a general nature or when normal conditions are not obtained during the pressure test.
- b) Certain faults can only be located and remedied by skilled personnel using special tools.
- c) If the compressor is damaged (e.g. defective valve plates) it is absolutely essential to replace the expansion valve as a possible cause of the malfunction.

Cause of faults in the electrical system

The individual circuits must be systematically checked with the aid of the circuit diagram (see Fig. 3.1) and the fault localized. Above all plug connections, switches, relays, etc., should be checked for continuity.

The following possibilities must always be checked and excluded as a possible cause of the malfunction:

- Defective fuses
- Corrosion of plug contacts
- Loose contact in plug connectors
- Wrong crimping on connector
- Corrosion on wiring and fuses
- Corrosion on battery poles

Cause of faults in the air-conditioning system

- Defective evaporator or condenser fan
- Contaminated or clogged air filters, evaporator or condenser fins
- Shortage of refrigerant in the system

If the system is deactivated continuously, we recommend that it be checked by an authorized workshop.

Dealing with problems in the refrigerant circuit

If faults arise in the refrigerant circuit, the system must be inspected and repaired by an authorized specialist repairshop. Refrigerant must never be discharged into the atmosphere (refer to Section 8 of the regulation dated 6 May 1991 banning the use of CFCs and halones).

Cause of faults making it impossible to reach the required states during pressure tests

Divergences from the required state during pressure tests (chapter 6.8) may be due to the following causes. These causes must be checked, the trouble located and defective components repaired or replaced.

High pressure gauge reading too high:

- Condenser air flow restricted
- Too much refrigerant

High pressure gauge reading too low:

- Not enough refrigerant (check sight glass)
- compressor speed too low (e.g. by slippage of V-belt)
- Compressor defective

Low pressure gauge reading too high:

- Expansion valve defective
- Compressor speed too low (e.g. by slippage of V-belt)
- Compressor defective

Roof-top air-conditioning system Easysphere

Low pressure gauge reading too low:

- Intake or delivery line restricted, e.g. by kinks
- Expansion valve defective
- Not enough refrigerant (check sight glass)
- Evaporator air flow restricted
- Clogged filter drier

6.7. Repairs

IMPORTANT

Refrigerant must never be discharged into the atmosphere (refer to Section 8 of the regulation dated 6 May 1991 banning the use of CFCs and halones).

NOTE

The safety precautions and regulations contained in chapter 1.4 and 6.2 must be observed.

Only genuine spare parts may be used for repairs and the original condition must be restored.

- a) Always use genuine spare parts or standard parts for repairs.
- b) The system's original condition must always be restored when performing repairs.
- c) Before opening / disassembling components in the refrigerant circuit, the refrigerant must be drained into the recycling station provided and disposed of properly or reused.
- d) After completing repairs on the refrigerant circuit, the system must be
 - evacuated in accordance with the operating instructions of the recycling station
 - filled with refrigerant on the high pressure side, with the system at rest
 - tested, see chapter 6.8.

6.8. Post-repair procedures and testing

Check refrigerant pressures and pressure switches function tests

e) General

As a rule, every air-conditioning system filled with refrigerant is a pressurized system. The pressure is the same throughout the system circuit and depends on ambient temperature.

During operation of the system, the working pressure on the intake side differs from that on the delivery side of the compressor. The pressures differ and are influenced by the compressor operating speed, the temperature inside the vehicle, the outside air temperature and relative humidity. Abnormal working pressures indicate that there is a fault in the system.

The working pressure should be tested with an on-board power supply of 24-26 V and at air temperatures between 20 °C and max. 40 °C. The fan must be operated at full power stage 3. The hood must be fitted for the pressure test since the air pressure of the heat exchangers has a decisive influence on whether or not the operating pressure is reached.

The following values must be obtained:

Outside air temperature	Low pressure gauge	High pressure gauge
27 °C	4.0 bar abs ± 0.2 bar	10 bar abs ± 2 bar
30 °C	4.2 bar abs ± 0.2 bar	11 bar abs ± 2 bar
35 °C	4.5 bar abs ± 0.2 bar	13 bar abs ± 2 bar
40 °C	4.9 bar abs ± 0.2 bar	15 bar abs ± 2 bar

If different pressure values are obtained, an authorized repair shop must be consulted to investigate the reasons.

When the pressure test is complete, disconnect the pressure gauges and refit the sealing caps.

f) Testing the high-pressure monitor

- Connect pressure gauges to system.
- Remove fuse F3 (condenser fan) and fit the hood.
- Switch on the air-conditioning system.
- Check whether compressor switches off at a pressure of 26.5 ± 2 bar.
- Remove the hood and refit fuse F3 (condenser fan).
- Check that compressor switches on again when pressure drops to 20 ± 2 bar.

g) Perform complementary steps.

IMPORTANT

If the high pressure switch is not working properly, switch off the air-conditioning system immediately to prevent undue refrigerant pressure buildup .

Replenishing partially filled systems with refrigerant

A sight glass is integrated into the circuit at the receiver-drier to check the refrigerant level. When correctly filled, refrigerant will flow through the sight glass without air bubbles roughly 5 minutes after starting the air-conditioning system. Occasional bubbles are meaningless. If gas bubbles are visible, the refrigerant quantity in the system has fallen below the minimum fill level.

6.9. Visual inspection

The system must be inspected visually as described in chapter 6.5 when the repairs are complete.

7. WARRANTY CLAIMS PROCESSING

- a) Parts subject to natural wear or which have been handled incorrectly are excluded from the warranty. The warranty period is not extended by repairs or delivery of replacement parts.
- b) In the event that a warranty claim arises, contact your local distributor/dealer in charge and provide the following:
 - part under warranty
 - warranty card
 - warranty claim form.